



Liberty II Wheelchair

—
User Instructions Manual & Warranty

Version 3. (September, 2019)

UCP |  **Wheels
for Humanity**

THANK YOU FOR PURCHASING A UCP LIBERTY WHEELCHAIR!

Please read this entire manual before using the Liberty wheelchair.

Before using the wheelchair, the user and his or her attendant should be trained in the safe use of this wheelchair by a qualified provider or a clinical professional.

If you have any questions or concerns about any aspect of this wheelchair or this manual, please do not hesitate to contact us:

By telephone: +1 818.255.0100

In writing: UCP Wheels for Humanity
9509 Vassar Avenue, Unit A, Chatsworth, CA 91311 USA

Or via email: info@ucpwheels.org

YOUR WHEELCHAIR SERVICE PROVIDER CONTACT INFORMATION

Name of the Wheelchair Service Provision Center/Institution:

Name of Wheelchair Service Provider:

Address:

Phone number:

Liberty Wheelchair Serial Number:

Date of wheelchair delivery: _____

TABLE OF CONTENTS

Thank you for purchasing a UCP Liberty wheelchair!	2
YOUR Wheelchair Service Provider contact information	2
Important information - Please read before using this Liberty wheelchair	5
<i>The user's safety and stability</i>	5
Liberty wheelchair's intended use	5
Warnings	5
<i>General warnings</i>	5
<i>Chest harness and pelvis strap</i>	6
<i>Using the wheelchair</i>	6
<i>Modifying your wheelchair</i>	7
How to setup, adjust and operate your wheelchair	8
<i>Know your wheelchair</i>	8
<i>The wheel locks</i>	9
1) <i>Operation</i>	9
2) <i>Adjustment</i>	9
<i>The seat</i>	10
3) <i>Seat cushion position</i>	10
4) <i>Proper fit</i>	11
<i>The knee separator pad (abductor)</i>	11
5) <i>How to attach, adjust and remove</i>	11
6) <i>Proper fit</i>	11
<i>The back support</i>	12
7) <i>Backrest cushion position</i>	12
8) <i>Proper fit</i>	12
<i>The lateral support pads</i>	12
9) <i>Proper fit</i>	12
<i>The pelvis strap and chest harness</i>	13
10) <i>Pelvis strap - How to fit and wear properly</i>	13
11) <i>Chest harness - How to fit and wear properly</i>	13
<i>The footrest</i>	14
12) <i>Proper fit</i>	14
<i>The headrest</i>	14
13) <i>Proper fit</i>	14
<i>The rear wheels</i>	14
14) <i>How to remove the rear wheels</i>	14
15) <i>How to attach the rear wheels</i>	15
<i>The armrests</i>	15
16) <i>Proper fit</i>	15
<i>The anti-tippers</i>	15
17) <i>How to attach</i>	15
18) <i>How to remove</i>	15
19) <i>Height adjustment</i>	15

<i>The tray</i>	16
20) <i>How to attach, remove and adjust the tray</i>	16
21) <i>Proper fit</i>	16
<i>How to transport your wheelchair</i>	16
How to ride in your wheelchair	17
<i>Moving while in the wheelchair</i>	17
<i>Ascending/descending stairs with your wheelchair</i>	17
<i>Sitting in your wheelchair</i>	18
<i>Transferring in and out of your wheelchair</i>	18
Pressure relief management and techniques	19
Cleaning, maintenance and repair	20
<i>How to take care of the wheelchair</i>	20
<i>Cleaning</i>	21
22) <i>Frame</i>	21
23) <i>Covers, chest harness, calf and pelvis straps</i>	21
24) <i>Cushions and pads</i>	21
25) <i>Rear wheels and front casters</i>	21
Troubleshooting	22
<i>What to do if you find an issue with the wheelchair during the inspections and maintenance activities</i>	22
<i>How to fix a flat tire</i>	22
Warranty	22
Other instructions	23
Quick Frame Assembly Guide	24
Quick Seat Unit Assembly Guide	26

IMPORTANT INFORMATION

Please read before using this Liberty wheelchair

The user's safety and stability

There are different types of wheelchairs that might meet the user's seating and mobility needs. You should consult a qualified wheelchair service provider when selecting the wheelchair type and setup that best meet the user's needs.

There are many factors affecting the wheelchair's stability, some of these include the wheelchair setup and environmental factors. The wheelchair's stability has a direct impact on the user's safety. The wheelchair setup should consider personal factors including user's abilities, strength, balance, and coordination. Any change made to the wheelchair setup will change the stability of the wheelchair. You should only make changes after consulting with a qualified wheelchair service provider.

LIBERTY WHEELCHAIR'S INTENDED USE

This wheelchair is intended for pediatric wheelchair users who require additional postural support in order to be able to sit upright.

WARNINGS

General warnings

The following warnings indicate imminent and/or potential hazardous situations which, if not avoided, could result in serious injury, death, or damage to the wheelchair.

Do not exceed the weight limit of 75 kilograms for the Liberty wheelchair. This is the combined weight of user and all items carried. Exceeding the weight limit can cause damage to the wheelchair or increase the likelihood of a fall or tip back.

Do not let the user attempt to push the wheelchair up or down ramps or traverse across a slope of greater than 10 degrees. This is dangerous and increases the likelihood of a fall or tip back.

Do not let the user attempt to push the wheelchair up an incline that is slick or coated with ice, oil, or water. This can cause an unstable situation.

Do not attempt to lift the wheelchair by holding on to removable parts such as the tray or push handle. This may cause a fall or loss of control. Only lift the wheelchair by holding on to the frame.

Do not overtighten the bolts and hardware that attaches various components together on the frame. This could cause serious damage and affect the safety and durability of the wheelchair.

This wheelchair is not designed to be used as an occupant seat in a motor vehicle. Always transfer the user out of the wheelchair when transporting the wheelchair.

Chest harness and pelvis strap

The chest harness and the pelvis strap are designed to assist with proper body positioning within the wheelchair. Use the chest harness and pelvis strap only to help support the user's posture. Misuse of the chest harness and pelvis strap may cause severe injury or death of the user.

Never use the wheelchair chest harness or pelvis strap as an occupant restraint in a motor vehicle. These are not designed as seat belts and will not prevent the user from being thrown forward during a sudden stop.

Ensure the user does not slide underneath the chest harness and pelvis strap in the wheelchair seating system. If this occurs, the user's breathing may be hampered causing death or serious injury.

Never use the chest harness without a pelvis strap. If used without a pelvis strap, the user can still slide down and the chest harness can cause strangulation.

Never fix the bottom of a chest harness to a pelvis strap. This will pull the pelvis strap up.

Do not over tighten the chest harness. It should have a snug fit and done up comfortably; tight enough to hold its position, but not so tight as to restrict breathing or pinch the skin.

Do not over tighten or loosen the pelvis strap in excess. It should provide firm, even contact. There should be no high-pressure points. These could cause pressure sores. If a pelvis strap is too loose, the wheelchair user can slide down. If not attended, strangulation may result. The pelvis strap should not be able to slide up onto the stomach.

Never use the chest harness or pelvis strap as a restraint or on a user who is unconscious.

Using the wheelchair

Use caution when pushing the wheelchair on a wet or slick surface. It can cause an unstable situation or loss of control.

Use caution when pushing the wheelchair over obstacles or road hazards. They can damage the wheelchair and may cause a fall, tip-over, or loss of control.

The Liberty wheelchair is made of many different materials including metal, plastic, foam, and fabric. Do not use the wheelchair in a shower, pool, or body of water. Exposure to water or excessive moisture may cause the metal in the wheelchair to rust or corrode, the foam to become moldy, and the fabric to tear. Dry the wheelchair as soon as possible if exposed to water.

Always clean the wheelchair after using it in sand or loose soil. Sand get into the wheel bearings and moving parts. This will cause damage and eventually will cause the wheelchair to fail.

Avoid pushing the wheelchair on public roads. Use caution if you must push the wheelchair on a public road.

Do not modify the wheelchair setup on your own. Always consult with a qualified wheelchair service provider before modifying the setup of the Liberty wheelchair. Moving the rear wheels forward, and/or tilting the seating system in excess could cause the wheelchair to tip backwards. Always use anti-tips while the user acclimates to any changes in the wheelchair setup.

Always consult with a qualified wheelchair service provider before readjusting the wheelchair for changes in the user's sitting, dimensions, or weight. Always check the fitting after the readjustment of the wheelchair.

Do not ascend/descend stairs with the anti-tippers attached or flipped down. Remove or flip the anti-tippers up before ascending or descending stairs. Make sure the anti-tips are reattached or flipped back down before riding the wheelchair.

Modifying your wheelchair

The Liberty wheelchair was designed and manufactured under internationally recognized quality standards for medical devices. It has been tested to various standards to ensure quality and durability.

Do not modify this wheelchair. No one should modify this wheelchair except a qualified wheelchair service provider or a qualified wheelchair technician. Use only assembling approved options and accessories. There are no approved options that involve drilling or cutting the frame by anyone.

HOW TO SETUP, ADJUST AND OPERATE YOUR WHEELCHAIR

Know your wheelchair

The picture below shows the parts and components of the Liberty wheelchair:

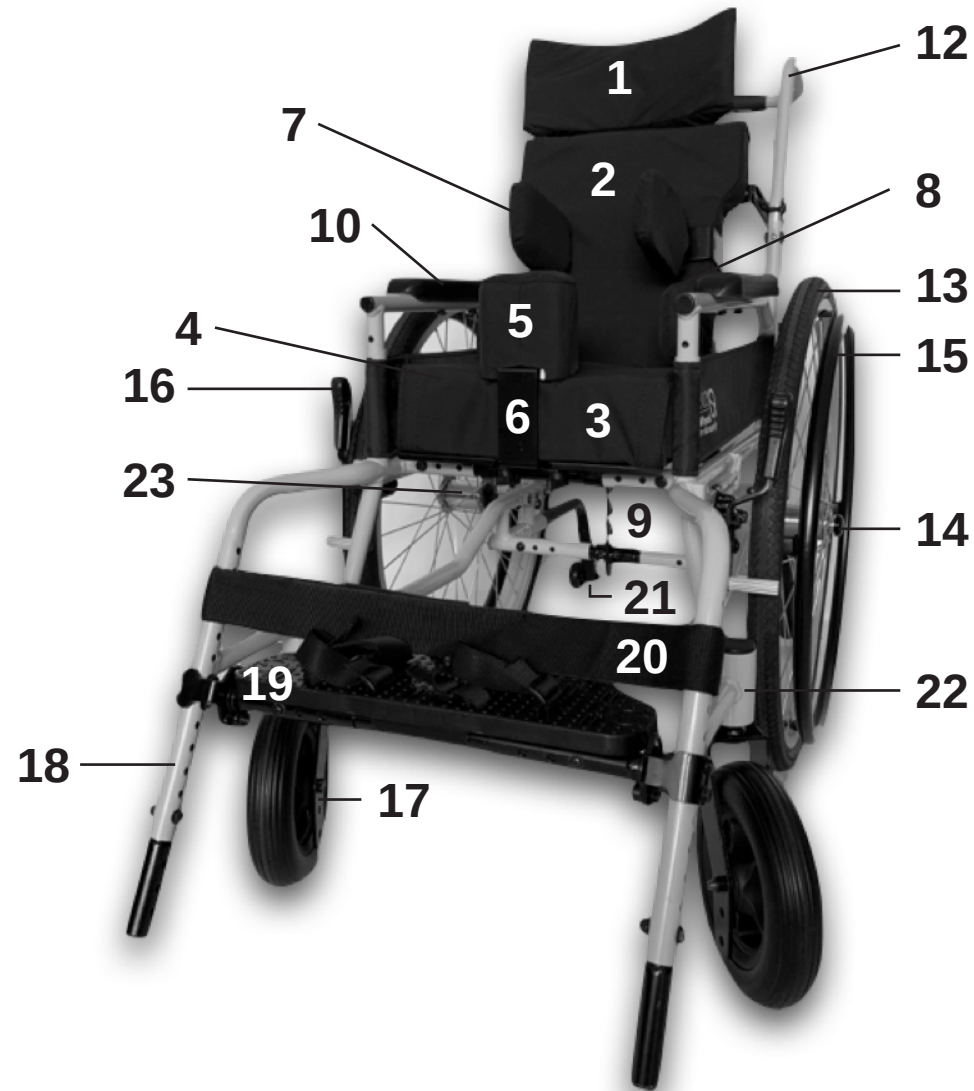

Seating system:

1. Headrest
2. Backrest
3. Seat
4. Pre-seat bone shelf
5. Knee separator pad (abductor)
6. Knee separator pad attachment
7. Trunk support pad
8. Pelvis support pad

Wheelchair frame:

- | | |
|----------------------------|-----------------------------|
| 9. Tilt-in-space mechanism | 18. Footrest tube |
| 10. Armrest | 19. Footplate |
| 11. Side guard | 20. Calf strap |
| 12. Push handle | 21. Anti-tipper |
| 13. Rear wheel | 22. Caster assembly housing |
| 14. Quick-release button | 23. Wheel axles |
| 15. Push-rim | |
| 16. Wheel lock | |
| 17. Front caster | |

The wheel locks

1) Operation

Use the wheel lock to prevent the wheelchair from moving once it is in complete stop position. Always engage the wheel locks before transferring the user in and out of the wheelchair and performing weight shifts.

Wheel locks are not meant to be used as brakes to stop or slow-down the wheelchair while moving.

To engage the wheel locks, push the wheel lock handles forward until the wheels lock in position Figure 1. To disengage the wheel locks, pull the lock handles back Figure 2.



Figure 1. Wheel lock - locked



Figure 2. Wheel lock - unlocked



Figure 3. Adjusting the wheel locks

Note – When locked, the rear wheels should not be able to spin. If any of the wheels spin with the wheel lock activated, you should adjust the wheel lock accordingly as described in the following section. Consult with your wheelchair service provider about how to adjust the wheel locks.

2) Adjustment

To adjust the wheel lock:

Use a 10mm wrench or socket to loosen domed cap nut. Slide mount forward or rearward to achieve proper locking as seen in Figure 3.

Retighten nut. Repeat for opposite side of the chair.

The seat

3) Seat cushion position

The seat of the wheelchair is comprised of different parts. The seat pan Figure 4 and the seat cushion and cover Figure 5.

Make sure the seat cushion is positioned correctly over the seat pan before using the wheelchair Figure 7.

To place the seat cushion on the wheelchair, align the hook Velcro on the top of the seat pan Figure 4 with the loop Velcro under the seat cover and press firmly Figure 6. The pre-seat bone shelf of the cushion should be located in the front Figure 7 (left) and the zipper side of the cover in the back. The front edge of the seat cushion should be aligned with the front edge of the seat pan Figure 7 (right).

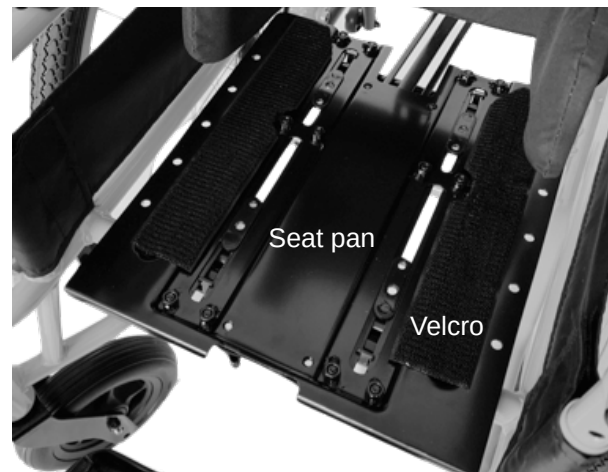

Figure 4. Seat pan



Figure 6. Placing the seat cushion correctly



Figure 5. Seat cushion with cover (bottom view)

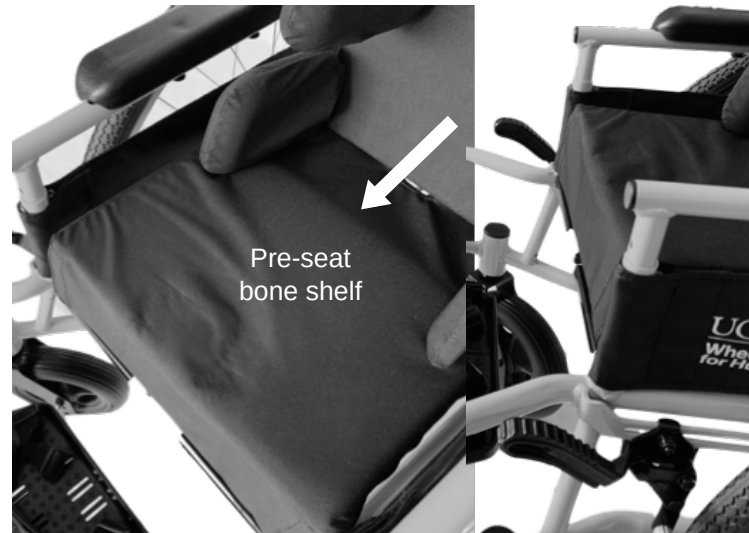

Figure 7. Seat cushion - correct position. Top view (left) and side view (right).

4) Proper fit

The seat width should fit closely¹:

- Make sure that the hips and thighs of the user fit comfortably between the pelvis side pads and/or the armrest tubes.
- The thighs should not be pushed together.

If you think the pelvis side pads are tight or the wheelchair is too narrow, contact your wheelchair service provider.

Seat depth²:

- There should be at least a 30 mm gap (60 mm for a user with longer legs) between the back of the knees and the front of the seat cushion while the user is sitting.
- The user's calves should not be touching the seat cushion.
- The pre-seat bone shelf should sit just in front of the user's seat bones.

If you think the seat is too long or too short, contact your wheelchair service provider to have the seat depth adjusted properly.

The knee separator pad (abductor)

5) How to attach, adjust and remove

Locate the two knob bolts under the front part of the seat pan and loosen (do not remove) Figure 8.

To remove the abductor, slide it out from the mount.

To attach the abductor, slide it into the mount until it reaches the desired position and retighten the knob bolts.

To adjust the abductor position, slide it forwards or backwards until it reaches the desired position and retighten the knob bolts.



Figure 8. Front-bottom view of the seat pan.

6) Proper fit

Make sure that there is no high pressure between the user's thighs and the abductor. The abductor should not put any pressure onto the groin area. It should be between 40–60 mm away from the user's groin area³.

The back support

The back support of the wheelchair is comprised of different parts. The backrest pan Figure 9 and the backrest cushion and cover.



Figure 9. Backrest pan with Velcro.

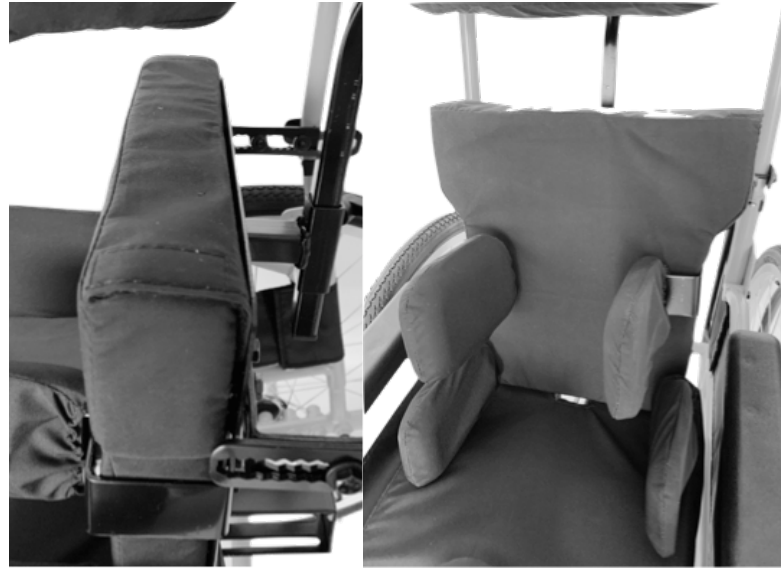

Figure 10. Backrest - correct position. Backrest cushion and pan correctly aligned upper view (left) and front view (right).

7) Backrest cushion position

Make sure the backrest cushion is positioned correctly over the backrest pan before using the wheelchair.

To place the backrest cushion on the wheelchair, align the hook Velcro on the front of the backrest pan Figure 9 with the loop Velcro on the backrest cover and press firmly. The top edge of the backrest cushion should be aligned with the top edge of the backrest pan Figure 10.

8) Proper fit

The height of the backrest should be at the top of the user's shoulders.
Contact your wheelchair service provider if you think the backrest height is too low or too high for the user.

The lateral support pads

9) Proper fit

The user's hips and thighs should fit closely and comfortably between the pelvis side pads which should be located below the hip joint. The thighs should not be pushed together⁴.

The user's trunk should fit closely and comfortably between the trunk side pads, which should not place any pressure into the armpits. There should be at least 50 mm between the user's armpit and the top of a trunk side pad⁵.

Make sure the trunk side pads do not interfere with the arm's movement if the user can self-propel.

Trunk and pelvis side pads should not prevent easy transfers in and out of the wheelchair, propelling, and accessing desks or tables.

Contact your wheelchair service provider if you think the pelvis and/or trunk side pads do not fit the user properly.

The pelvis strap and chest harness

10) Pelvis strap - How to fit and wear properly

Pull the pelvis straps over the user's lap at 90° from the seat. Make sure the pelvis strap padding is at the same level on both sides and neither strap has any twists in it. Buckle the pelvis strap and adjust the strap length to a snug tightness by pulling the straps in and out of each side release buckle Figure 11. Make sure the buckle is centered in the user's lap.



Side release buckle

Figure 11. Pelvis strap

The pelvis strap should be tightened firmly and not pinch the user's skin (run hands between the strap and the user to check).

11) Chest harness - How to fit and wear properly



Pull the chest harness over the user. Make sure all the harness straps are at the same level and neither strap has any twists in it. Buckle all the harness straps and pull the straps to a snug tightness.

The upper curved edge of the center of the harness Figure 12 should be positioned at the armpit level.

The shoulder harness should be done up comfortably and not pinch the skin.

The footrest

12) Proper fit

The user's thighs should be fully supported on the seat cushion with no gaps. Pressure under the thighs and butt should be evenly distributed⁶.

The user's feet should be fully supported on the footrests with no gaps. The feet should be supported at the front and the back⁷.

If there are gaps under the thighs, the footrest may be too high. If there are gaps under the foot, the footrest may be too low.

Contact your wheelchair service provider if you think the footrest is too high or too low for the user.

The headrest

13) Proper fit

The headrest should support the user's head at the base of the skull. The user's head should be in a balanced and up-right position.

Contact your wheelchair service provider if you think the headrest does not support the user's head properly.

The rear wheels

14) How to remove the rear wheels

Hold the rear wheel close to the hub and push the quick-release button on the outside end of the axle Figure 13 to allow the locking balls on the end of the axle to retract Figure 14.

While still holding the button, pull the wheel and the axle out of the axle sleeve.

Repeat with the other rear wheel.



Figure 13. Quick-release button of the rear wheel axle.



Figure 14. Locking balls



Figure 15. Attaching/removing rear wheel axle from axle sleeve.

15) How to attach the rear wheels

Identify the quick release button on the axle of the rear wheel Figure 13 and push it to allow the locking balls on the end of the axle Figure 14 to retract and slide the axle into the axle sleeve.

Release the quick-release button to lock the axle in sleeve Figure 15. The quick-release button should fully extend, and the locking balls should move into the locked position after releasing the button.

The armrests

16) Proper fit

The armrest should be at the user's elbow level without elevating or depressing the user's shoulders.

Contact your wheelchair service provider if you think the armrests are too high or too low for the user.

The anti-tippers

17) How to attach



Figure 16. Anti-tipper's pins for attachment.



Figure 17. Anti-tipper's pins aligned with holes in frame tubes.

Press both pin buttons at the end of the anti-tipper without the caster Figure 16.

Align anti-tipper pins with the holes in the frame tube of the anti-tip attachment and insert the anti-tipper into the frame tube until the pins latch into position Figure 17. Repeat for the other anti-tip.

18) How to remove

Press both pin buttons at the end of the anti-tipper closer to the frame Figure 17 and pull the anti-tipper out of the frame tube while still holding the pin buttons. Repeat for the other anti-tipper.

19) Height adjustment



Figure 18. Anti-tipper adjustment

Press both pin buttons at the end of the anti-tipper with the caster and slide the anti-tip extension tube up or down Figure 18 so that 1.5" to 2" gap is achieved between the floor and the bottom of the anti-tip wheel.

Align the holes of the anti-tip extension tube (outer tube) with the pins until they latch into desired position.

Repeat for the other anti-tipper. Ensure that both anti-tippers are set up identically.

The tray

20) How to attach, remove and adjust the tray

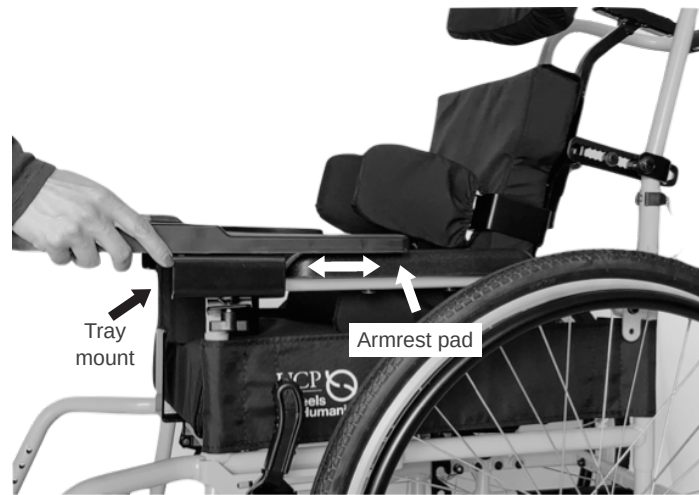

Figure 19. Tray attachment, adjustment and removal.

To attach, align the tray attachment mounts with the armrest pads of the wheelchair and insert the tray Figure 19. Slide backwards until desired position and tighten the knob screws.

To adjust, slide the tray forwards or backwards on the armrest pads of both sides Figure 19 until it reaches the desired position.

Refer to Proper fit section below on how to fit the tray properly.

To remove, slide the tray out of the armrest pads Figure 19.

21) Proper fit

The tray should support the length of the forearm and elbows and not push on the stomach or rub on the user's skin⁸.

The tray should not be used to 'restrain' a user in their seat.

How to transport your wheelchair

To transport the wheelchair in a vehicle you will need to transfer the user out of the wheelchair first. After you have removed the user from the wheelchair, follow the next steps:

1. Remove the rear wheels. Refer to page 17 of this manual.
2. Lift the wheelchair frame from a non-removable part and load it into the vehicle. Load the two rear wheels.
3. Re-attach the rear wheels after unloading the wheelchair from the vehicle.

HOW TO RIDE IN YOUR WHEELCHAIR

Note - The following information is not to replace proper training provided by a qualified wheelchair service provider. The user should receive training from a qualified professional according to his/her abilities and environmental characteristics before using the wheelchair.

Moving while in the wheelchair

Note - Every wheelchair user is different and so are their skills in riding their wheelchair. The user and his/her attendant should receive training from a qualified wheelchair service provider on how to best propel the wheelchair before using it.

To propel the wheelchair⁹:

- If a self-propeller, it is recommended that the user pushes from 10 o'clock to 2 o'clock position (as much as possible) using a long smooth action to push.
- To turn, hold one push rim towards the front and the other towards the back; pull the forward hand backwards and push the backward hand forwards at the same time.
- If the user needs assistance to push the wheelchair, the attendant should push the wheelchair from behind, from the push handle, making sure the user's arms and hands are not in contact with the wheels
- Keep a lookout for potential dangers in the area well ahead of the wheelchair.

To go up slopes¹⁰:

- The user should lean the upper body forward slightly– this helps to stop the wheelchair tipping.
- To stop or rest – park the wheelchair sideways on.
- If the wheelchair has anti-tippers, lock them in place before going up.

To go down slopes¹¹:

- The user should press the upper body backwards as he/she goes down.

Never leave a user unattended when going up or down a slope.

Ascending/descending stairs with your wheelchair

Have at least two people, who have sufficient strength and skill to handle the weight of the user and wheelchair, assist when trying to go up or down a set of stairs in this wheelchair.

To go up the stairs¹²:

- Move the wheelchair and user backwards up the stairs.
- Position one person behind the user, one person in front.
- The rear attendant tilts the wheelchair backwards on to the back wheels, positioned against the first step.
- The rear attendant pulls back and upwards, rolling the wheelchair up. Take one step at a time.
- The second assistant can help by holding on to a non-removable part of the wheelchair frame from the front.

To go down¹³:

- The user should be facing forward.
- The rear attendant tilts the wheelchair backwards on to the back wheels and lets the wheelchair roll down the stairs slowly, one step at a time.
- The second assistant can help by steadying the wheelchair from the front, holding on to a non-removable part of the wheelchair.

Note – These actions may require that anti-tippers be flipped up or removed. Make sure the anti-tippers are reattached or flipped back down before using the wheelchair.

Sitting in your wheelchair

Make sure the user is sitting correctly while in the wheelchair. The user should be positioned well back in the wheelchair with the seat bones behind any pre-seat bone shelf and the back of the pelvis supported on the backrest. Consult with your wheelchair service provider on how to properly sit the user in the most upright, balanced, and comfortable position possible.

Some users may not be used to sitting very much, it may take time for them to become used to sitting in an upright posture¹⁴. Consult with your wheelchair service provider on how long the user should sit in the wheelchair. Do not let the user spend all day sitting in a wheelchair.

If the user has very limited movements, tends to sit in the same posture all the time and cannot change position, consult your wheelchair service provider about other positions the user can use during the day. For example, lying or standing.

If the user is used to sitting, he/she may spend the same amount of time sitting in their new wheelchair. Gradually increase the time, if needed.¹⁵

If the user is not used to sitting up, start with no more than 30 minutes followed by a break.¹⁶

Check for pressure areas under the user's seat bones or any other area at risk every day after the user has sat in the wheelchair.

Make sure the user cannot slide down the seat. Make sure the pelvis strap is done up firmly and keeps the pelvis positioned.

Transferring in and out of your wheelchair

A transfer requires good balance and stability from the user (if the user can transfer independently) and the person assisting or lifting. The user and the person assisting should receive training from a qualified wheelchair service professional before attempting to do a transfer. The wheelchair service provider should teach them a safe and quick transfer method, according to their needs, that is comfortable and safe for both.

Before transferring the user in or out of the wheelchair, position the wheelchair sideways to the transfer surface. Every caution should be taken to reduce the gap between the two surfaces.

Always engage the wheel locks to lock the rear wheels before the transfer and rotate the casters forward to increase the wheelbase of the wheelchair.

Make sure all straps and chest harness are undone before transferring the user out of the wheelchair.

Make sure that no part of the user's body hits or rubs the wheelchair while transferring. This may contribute to a pressure sore development. Do not let the user fall abruptly in to the wheelchair. If lift-transferring, always place the user in to the wheelchair slowly and carefully.

Have someone assisting you unless you are well experienced in transfers.

Make sure the user is seated in a good sitting position after transferring him/her in to the wheelchair.

PRESSURE RELIEF MANAGEMENT AND TECHNIQUES

Pressure sores can develop for many reasons including sitting too long, poor posture, uneven weight distribution, rubbing, high-pressure points between the user's body and the position support devices, lack of sensation, bowel and bladder problems, immobility, weight, etc¹⁷. The user and his/her attendant should be referred to a medical professional to receive proper advice on how to prevent and manage these complications. They should also receive proper training from a qualified wheelchair service professional on pressure relief management and techniques.

Make sure the user is sitting correctly, has good postural support and sits as upright, balanced and comfortably as possible. Good postural support is important to help improve posture, distribute weight evenly, and reduce shear forces which, in turn, will reduce the risk of pressure sore development¹⁸. Adjustment of the wheelchair and its postural support elements may be needed. Always consult with your wheelchair service provider before making any adjustment to the wheelchair and its configuration.

If the user has very limited movements, tends to sit with the same posture all the time and cannot change position, consult your wheelchair service provider about other positions the user can use during the day. Changing position regularly helps to relieve pressure. For example, change the position from sitting to lying.

Assist the user to perform a weight shift every 15-30 minutes for at least 30 seconds to 2 minutes by bending his/her upper body forward.¹⁹ Maintaining the weight shift for longer periods of time is recommended (up to 4 minutes.)

Do not let the user spend all day sitting in a wheelchair.

Check the pressure between the wheelchair user's body part and the postural support devices such as the pelvis/trunk side pads and the knee separator pad. These should fit closely and comfortably. There should be no high-pressure points. Consult with your wheelchair service provider if you think the user has grown and adjustments to the wheelchair are needed.

Check the pressure between the wheelchair user's body and the pelvis strap/chest harness. Support should feel firm – but not tight.

Check the skin for signs of pressure under the user's seat bones and any other area at risk (e.g. under the hip joint or tail bone) after the user has sat in the wheelchair.

A damp or soiled seat cushion can cause the skin to break down. In addition, bacteria present in feces rapidly leads to infected pressure sores. The waste products in urine and feces can also infect sores and burn the skin. Make sure the seat cushion is dry, clean and in good working condition at all times. Stop using the seat cushion if it is wet, let it dry first.²⁰

Make sure that no parts of the user's body are being rubbed by the wheelchair, put special attention that his/her arms and hands are not rubbing against the rear wheels while in motion. This can break the skin.

Handle the user carefully when transferring him/her in and out of the wheelchair. Hitting his/her body against the wheelchair while transferring can damage the skin.

If you notice a red or dark mark in the user's seat bones or any other area at risk of pressure sores, take the user out of the wheelchair immediately. Check the skin again after 30 minutes, if the redness or change in color has not faded, stop using the wheelchair and contact your wheelchair service provider as soon as possible.

If you notice a wound in the user's seat bones or any other area at risk of pressure sores, stop using the wheelchair immediately and contact your wheelchair service provider and a medical professional as soon as possible.

CLEANING, MAINTENANCE AND REPAIR

The following activities are recommended in order to extend the life of the wheelchair and improve its performance. The user and his or her assistant should receive proper training from a qualified wheelchair service provider or technician before attempting to do any wheelchair maintenance on their own. Wheelchair repairs and replacement of parts should be done by a qualified wheelchair technician.

How to take care of the wheelchair

Contact your wheelchair service provider if you find any problem with the wheelchair during the following inspection and maintenance activities.²¹

We recommend you do the following activities weekly:

- Check the pressure of the tires. The tires should be properly inflated at 60 PSI. Inflate the tires if needed. The Liberty wheelchair comes with an air pump Figure 20. Contact your wheelchair service provider if any of the tires is flat.
- Check the seat and backrest cushions, lateral side pads and all the covers. The covers should be in good condition, clean, and not have any holes or tears; the zippers should be working well; and the Velcro strips should not be worn or torn. The foam and padding should not be deteriorated or chipped and should bounce back when pressed.
- Check the rear wheels. Check the tires for tread wear. Replace tires if they have flat spots, cracks, or worn-out tread. All the spokes should be tightened equally, and not missing, broken, or bent. Both rear wheels should roll straight with no excess drag, pull, side motion or rubbing. The axles should be properly tightened with no excessive play. The quick-release buttons should slide through the axle sleeve smoothly and lock into position. The push-rims should be tightened to the wheels and should not be dented or bent.
- Check the front casters. Both should be touching the floor evenly and be vertically aligned. The caster wheels should not be worn out or cracked and spin freely around its axle. The caster assembly bolt should be tight and have a cap. The caster assembly should rotate around its axle freely and without excessive play.
- Check the wheel locks. As tires wear the wheel locks should be adjusted. They should be tightly attached to the frame and properly engage the tires. Refer to page about how to adjust the wheel locks and contact your wheelchair service provider if they are not working properly.

We recommend you do the following activities monthly:

- Check all the fasteners on the wheelchair frame and seating system. Make sure they all are tight and secure. Unless otherwise noted, fasteners should be tightened snugly. Do not over tighten. If any fastener is missing, stripped or broken, contact your wheelchair service provider. The Liberty wheelchair comes with a Maintenance and Assembly Toolkit Figure 21 with the appropriate wrench, socket, and screwdriver sizes.
- Check the seat and backrest pans for cracks, dirt, fractures, or any metal part that may be sticking out.
- Check the anti-tippers. They should lock into place properly and not have any broken parts (including the small caster).
- Check the frame, weld points, holes, and bends to confirm that they are intact. Contact your wheelchair service provider immediately if you identify any crack or fracture in the frame.
- Once a year have the wheelchair checked by a qualified wheelchair technician.



Figure 21. Hand tools included in the Liberty's Maintenance and Assembly toolkit.

Cleaning

22) Frame

Remove the seat and backrest cushions from the frame.

Remove any other fabric covers from the frame, calf strap, chest harness, and pelvis strap.

Wipe down the wheelchair frame, at least once a month, with a clean, damp rag and pH balanced soap (like a dedicated car-wash product).

Take the rear wheels off for better cleaning of the frame.

23) Covers, chest harness, calf and pelvis straps

Take all the fabric covers off and hand wash with mild soap. Dry in the shade.

24) Cushions and pads

Remove the cover.

Lay the foam cushion or pad on a surface that can get wet.

Fill a spray bottle with one-part mild soap liquid detergent and two-parts warm water. Shake the spray bottle to mix the solution.

Spray the entire surface cushion or pad. Flip it over and repeat on the other side. Once you've finished spraying both sides, let the soap solution set for 20 to 30 minutes.

Wipe the soap solution off with a damp washcloth. Do not spray with water.

Allow the material to air dry but avoid direct sunlight. Depending on how wet the foam is, it may take 24 hours to several days to completely dry.

Put the cover back on each cushion in the correct orientation (zipper rear or downwards).

25) Rear wheels and front casters

At least once a month, remove lint and hair build up from the axle bearings of the rear wheels and caster wheels. Contact your wheelchair service provider if you hear any noise or if the wheelchair has become harder to push.

Clean around the rear wheel axles and the axle sleeves with a damp rag weekly.

Every six months disassemble the caster housing to remove entangled hair.

Do not use WD-40 or any other penetrating oil in this wheelchair. Do not use any chemical cleaning agents on casters or tires.

TROUBLESHOOTING

What to do if you find an issue with the wheelchair during the inspections and maintenance activities

Contact your wheelchair service provider for any problem with the Liberty wheelchair, components or function. Refer to page for contact details of your wheelchair service provider.

How to fix a flat tire

The Liberty wheelchair includes a flat tire repair kit Figure 22. We recommend you contact a qualified wheelchair technician or bicycle shop in order to repair a flat tire unless you are qualified to do it. Follow the illustrated instructions in the kit to repair the flat tire.



Figure 22. Flat tire repair kit.

WARRANTY

Wheelchair frame - defects in materials and workmanship for 18 months.

Components (wheel locks, caster forks, brackets, seating system structure) for 6 months.

Wearing parts (tires, tubes, casters, bearings, postural support elements, cushions, upholstery) guaranteed to be in good condition when received, however normal wear and tear are not warrantied.

OTHER INSTRUCTIONS

QUICK FRAME ASSEMBLY GUIDE

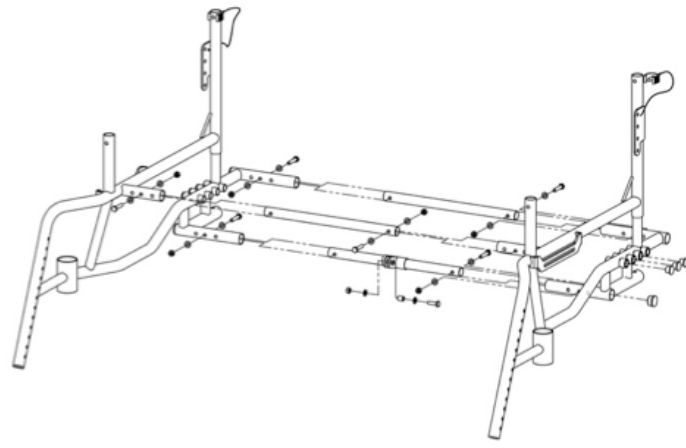

Step 1: Assemble the right and left frame tubes.

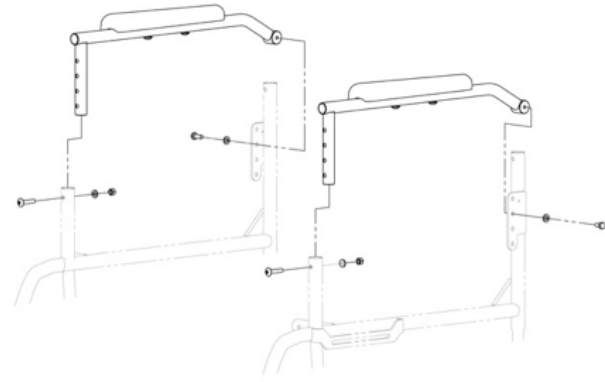

Step 2: Assemble the armrests.

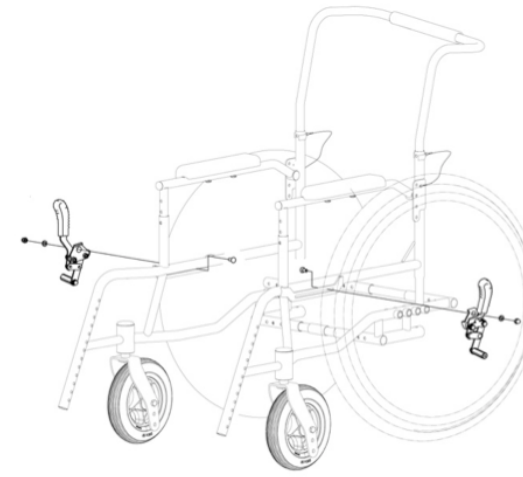

Step 7: Assemble the wheel-locks.

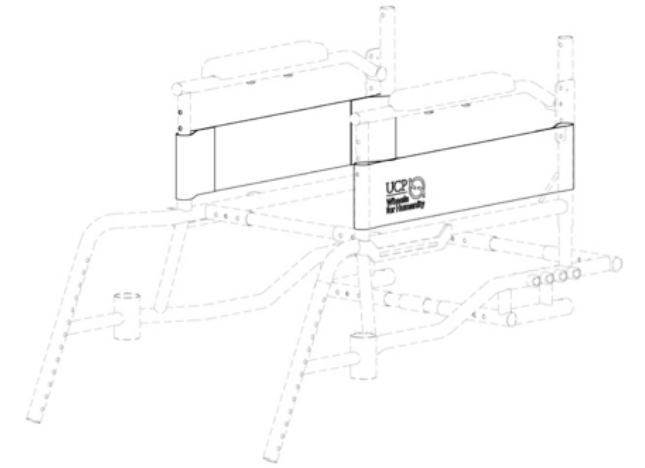

Step 8: Attach the side guards.

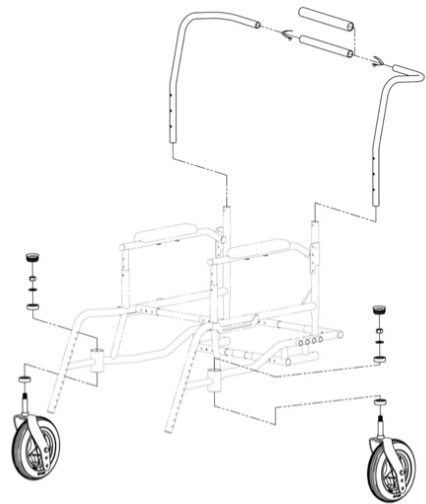

Step 3: Assemble the front casters and push handle.

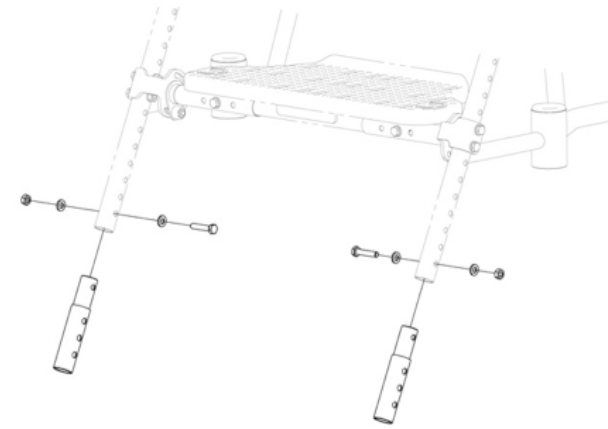

Step 4 (optional): Assemble the footrest tube extensions.

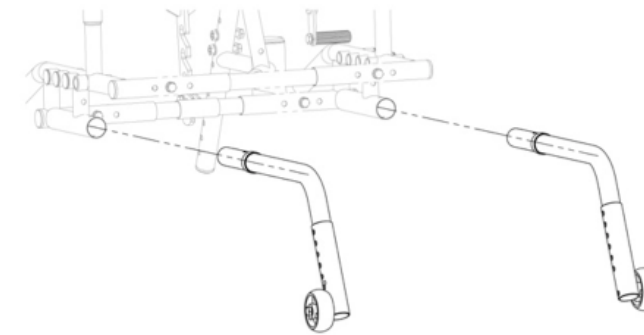

Step 9 (Optional): Assemble the anti-tippers.

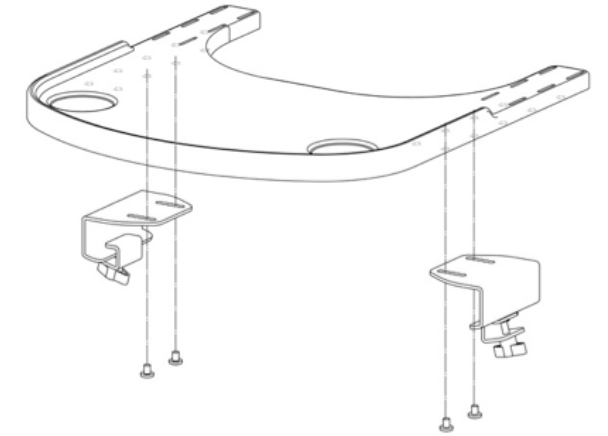

Step 10: Assemble the tray.

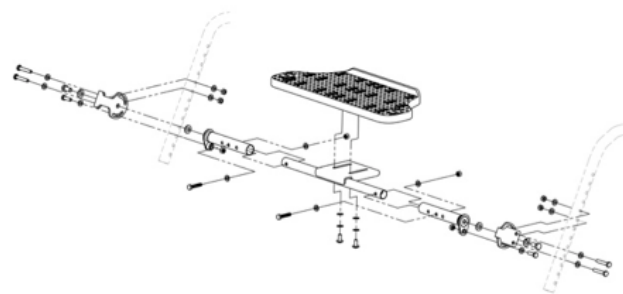

Step 5: Assemble the footrest.

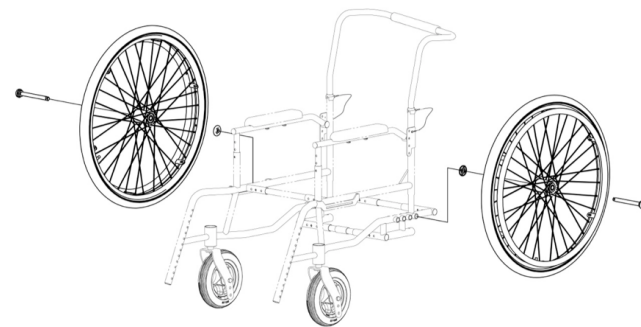

Step 6: Attach the rear wheels.

QUICK SEAT UNIT ASSEMBLY GUIDE

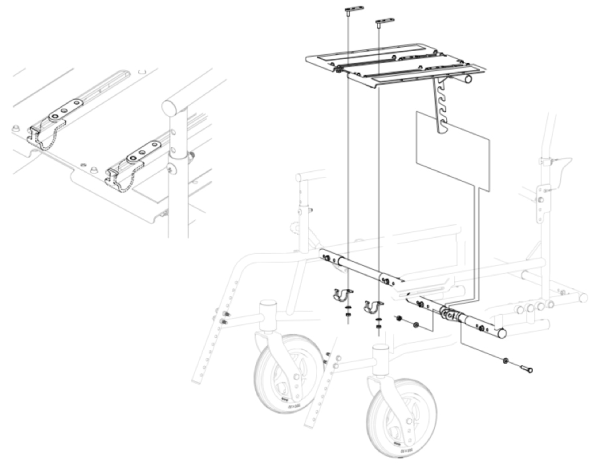

Step 1: Attach the seat pan and the tilt mechanism to the frame.

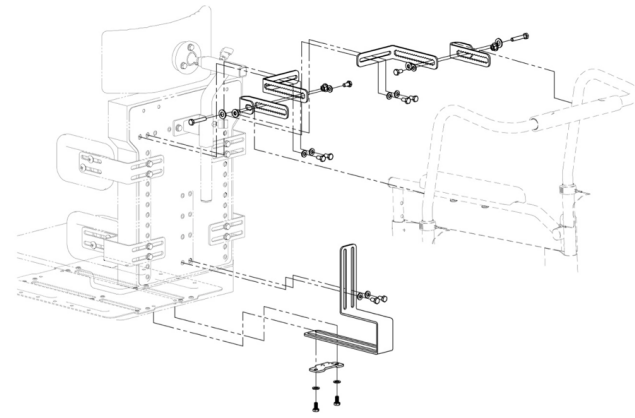

Step 2: Attach the backrest pan to the seat pan and the back-frame posts.

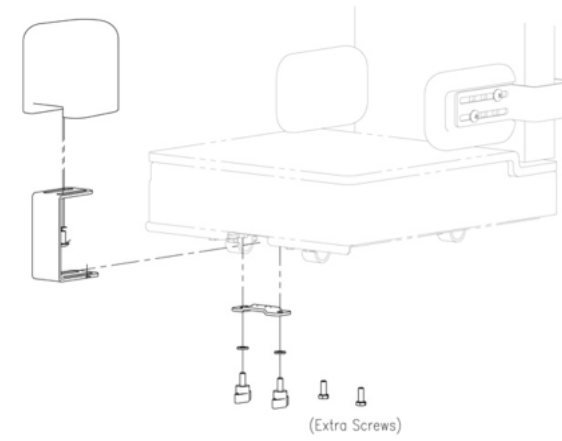

Step 7 (optional): Attach the abductor.

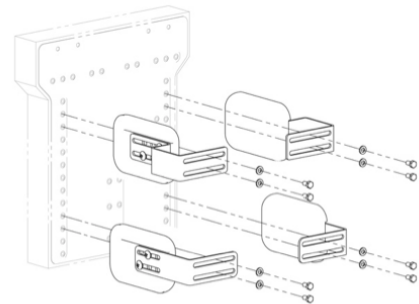

Step 3: Attach the lateral support pads (4) to the backrest pan.

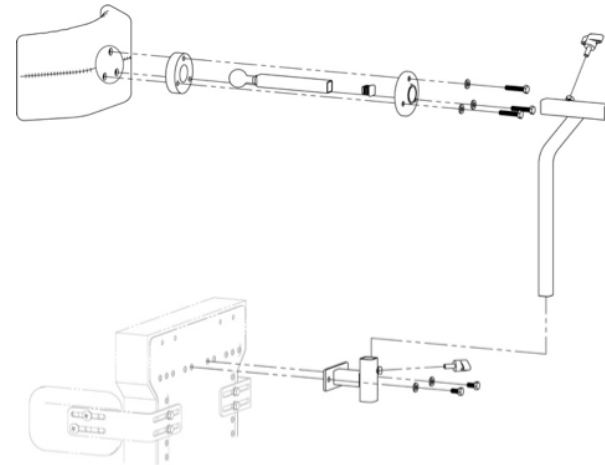

Step 4: Attach the headrest to the backrest pan.

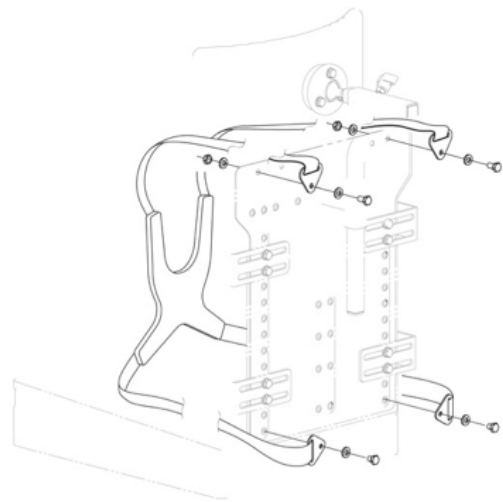

Step 5: Attach the chest harness to the backrest pan.

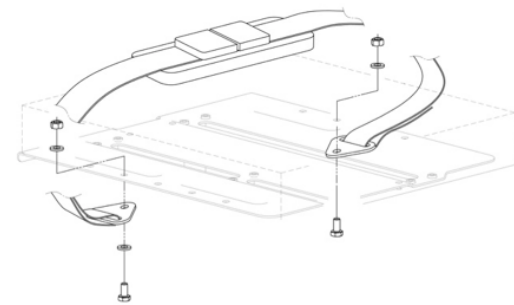

Step 6: Attach the pelvis strap to the seat pan.

UCP |  **Wheels
for Humanity**